

High Pressure Fan



Effectively creates a safe and comfortable environment by replacing the indoor stale air with fresh outside air



Product Characteristics

“Triple W” reduces noise

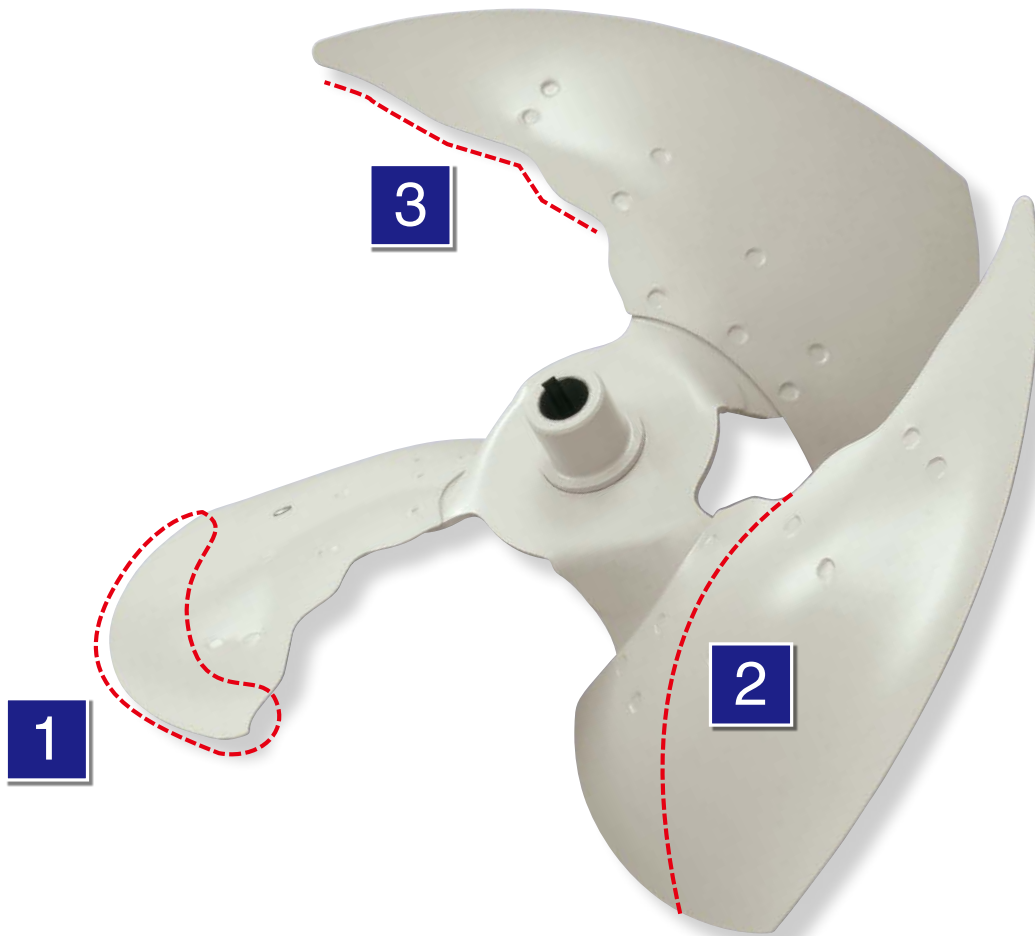

1 “Winglet” design

Specially designed winglets disperse noise-causing vortices

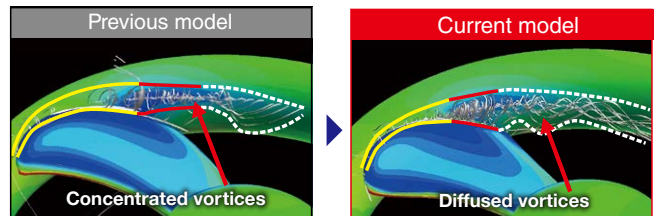

2 Front-side “Warp”

The curvature radius has been optimized to minimize trailing-edge vortices

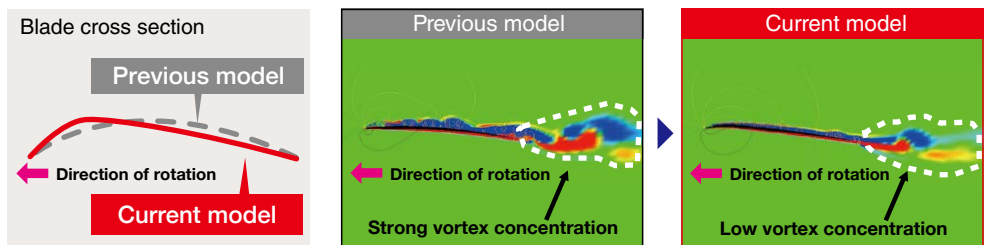

3 “Wave”-shaped blade edge

The wave-shaped edge breaks down the separation vortex into smaller, controlled vortices

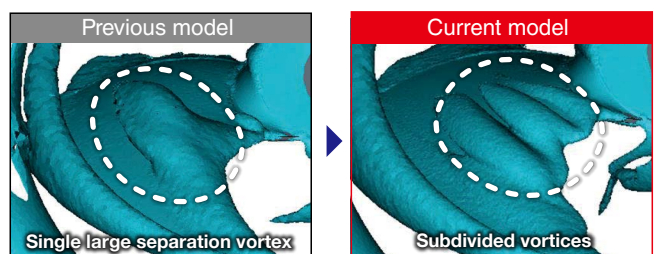

Noise-reducing Technology

Compared with the previous model, the current models all reduce noise by more than 3.5 dB, and by a maximum of 6dB with “Triple W” technology.

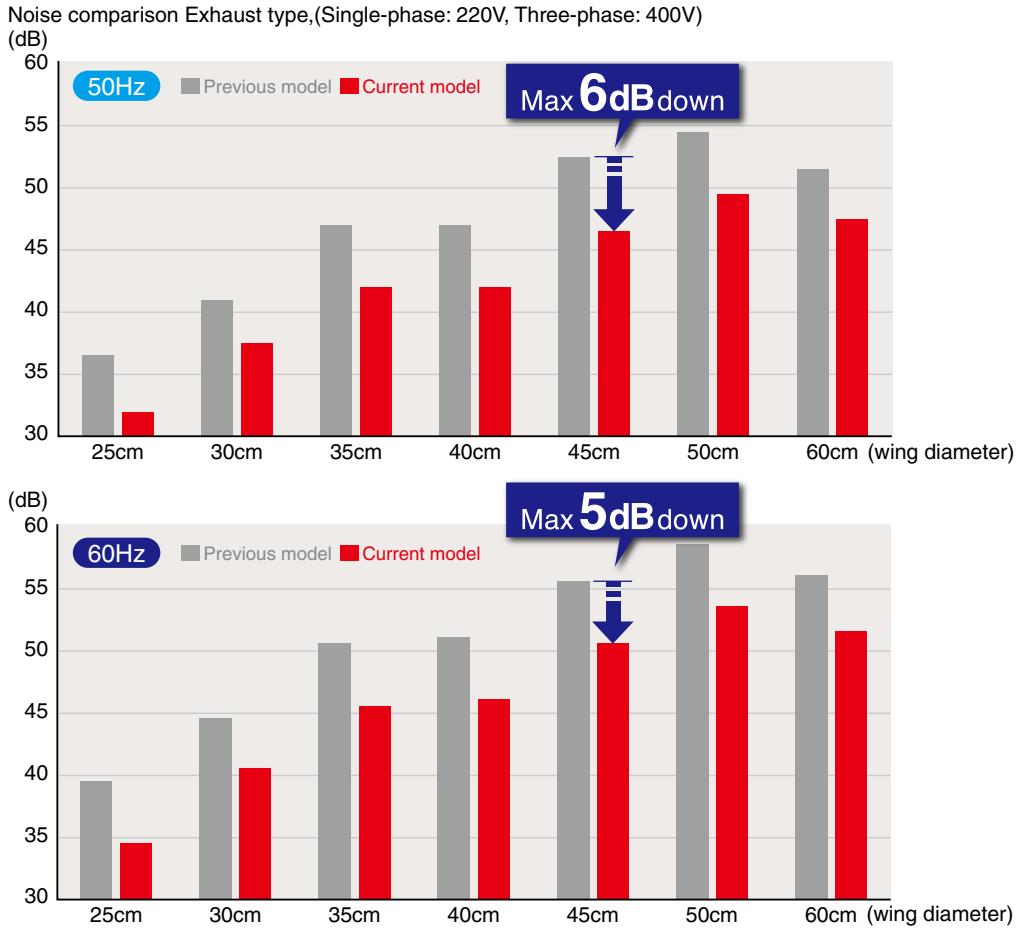

Increased Reliability

By introducing a new heat-resistant urethane-type grease, the motor axis has become approximately three times more reliable than previous models.

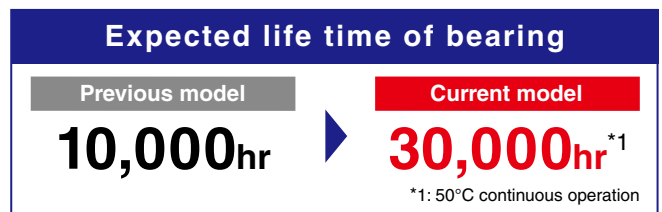

Easy Installation

By eliminating the corner piece, installing the fan with nuts has become easier.

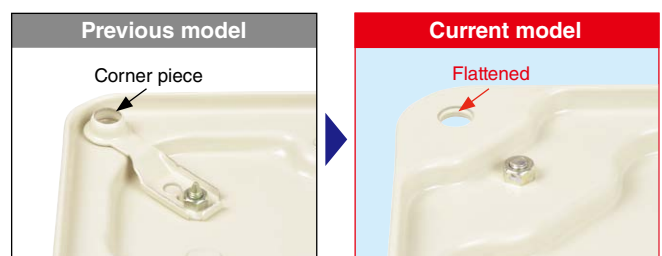



EWF-25 to 45-E (Exhaust type)

- *For exhaust use only.
- *This series are not for supply use (the direction of the vanes cannot be changed). For supply-use models, please see p.5.
- *Operating conditions: Ambient temperature between -15°C and +50°C, and a relative humidity of 90% or less at normal temperature. Use outside of this range may result in burning, deformation, irregular rotation, or damage.
- *Do not install the unit in a freezer or where freezing may occur.
- *Avoid turning the unit on and off more than 50 times a day.
- *Speed switching is not possible with this series.
- *Do not install the indoor models outdoors where they will be exposed to direct rain.
- *Do not connect the unit to an inverter (the insulation may break down due to a surge from the inverter).

■Dimensions EWF-25 to 45-E

*The appearance may differ slightly depending on the model.

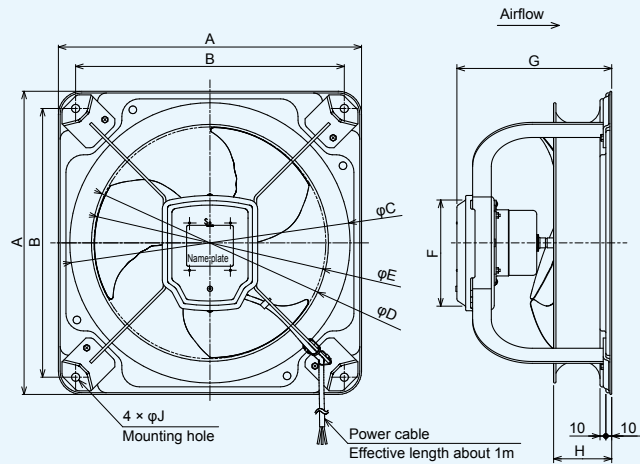

Unit : mm

■Dimensions

Model	A	B	C	D	E	F	G	H	J	Power cable
EWF-25ASA-E	370	330	310	266	260	153	201	65	φ10	X
EWF-30BSA-E	420	380	359	306	300	153	197	69	φ10	X
EWF-35DSA-E	470	434	419	356	350	181	259	93	φ10	X
EWF-40DSA-E	520	460	480	406	400	181	266	99	φ14	X
EWF-45ESA-E	620	560	540	456	450	211	307	111	φ14	X

X : Vinyl cabtyre cable 3 conductors x AWG18

Applicable for



■Specifications (50Hz)

Model	Power supply [V]	Number of poles	Power consumption [W]	Current [A]	Airflow rate [m³/h]	Noise [dB]	Weight [kg]	Indoor/outdoor use
EWF-25ASA-E	Single-phase 220-240	4	42-48	0.21-0.23	1150	32	3.9	Indoor use
EWF-30BSA-E		4	59-68.5	0.32-0.36	1680	37.5	5.7	
EWF-35DSA-E		4	125-138	0.70-0.75	3000	42	9.4	
EWF-40DSA-E		4	128-138	0.64	3720	42	12.1	
EWF-45ESA-E		4	253-275	1.33-1.38	5560	46.5	19	

■Specifications (60Hz)

Model	Power supply [V]	Number of poles	Power consumption [W]	Current [A]	Airflow rate [m³/h]	Noise [dB]	Weight [kg]	Indoor/outdoor use
EWF-25ASA-E	Single-phase 220-240	4	46-52	0.21-0.22	1260	34.5-35	3.9	Indoor use
EWF-30BSA-E		4	67.5-74	0.31-0.32	1900	40.5-41	5.7	
EWF-35DSA-E		4	170-178	0.80	3500	45.5	9.4	
EWF-40DSA-E		4	175-190	0.80	4200	46	12.1	
EWF-45ESA-E		4	350-360	1.60-1.50	6370	50.5	19	

P-Q Characteristics

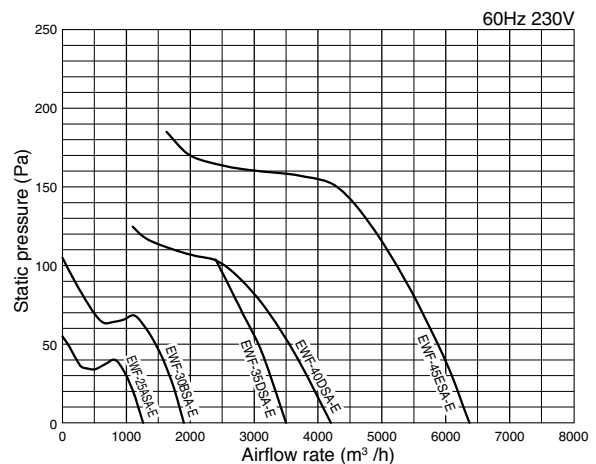
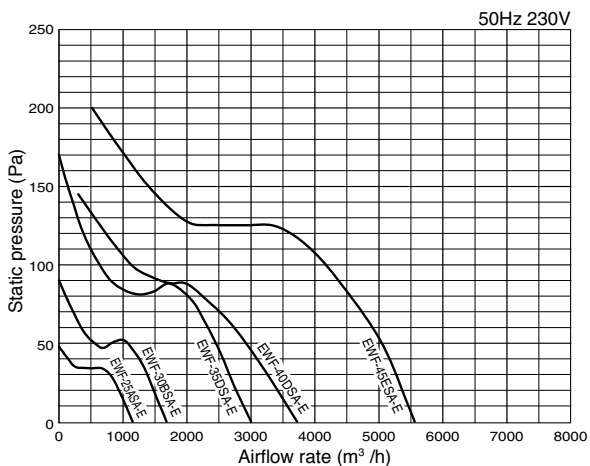

*Do not use the appliance out of the range of the characteristic curve.

The printed color of the products may differ slightly from the actual product colors.
Due to continuous improvements, the above specifications are subject to change without notice.

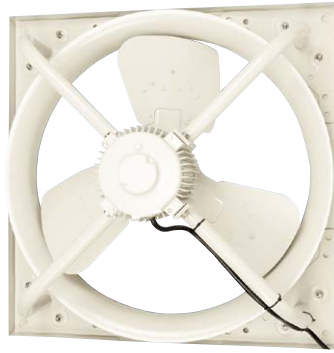

EWF-45 to 50-E
EWG-60-E
(Exhaust type)

KG-70 to 80-E
EJ-105-E
(Exhaust type)

- *45-60cm models are for exhaust use only (the direction of the vanes cannot be changed). For supply-use models, please see p.5.
- *Operating conditions: Ambient temperature between -15°C and +50°C (for the 105cm model, between -30°C and +50°C), and a relative humidity of 90% or less at normal temperature. Use outside of this range may result in burning, deformation, irregular rotation, or damage.
- *Do not install the unit in a freezer or where freezing may occur.
- *Avoid turning the unit on and off more than 50 times a day.
- *Speed switching is not possible with this series.
- *Outdoor models may be installed where they will be directly exposed to rain. However, rust could shorten their service life.
- *Do not connect the unit to an inverter (the insulation may break down due to a surge from the inverter).

Applicable for



KG-70GTF₃-E and KG-80HTF₃-E can be used as supply-type units by changing the direction of the vanes and wiring connection. Please refer to the manual on how to make these changes. (Please see p.5 for the specifications and P-Q characteristics.)

■Dimensions *The appearance may differ slightly depending on the model.

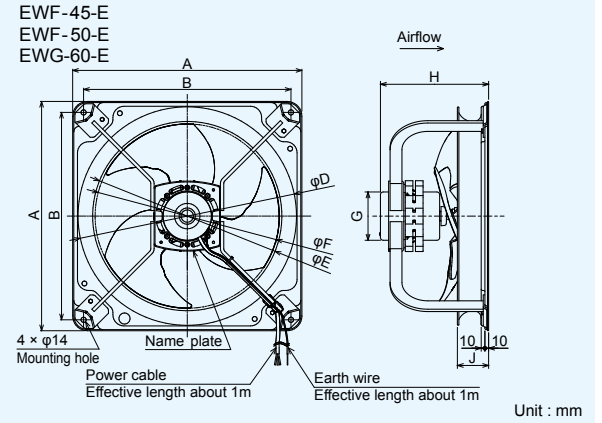

■Dimensions *The appearance may differ slightly depending on the model.

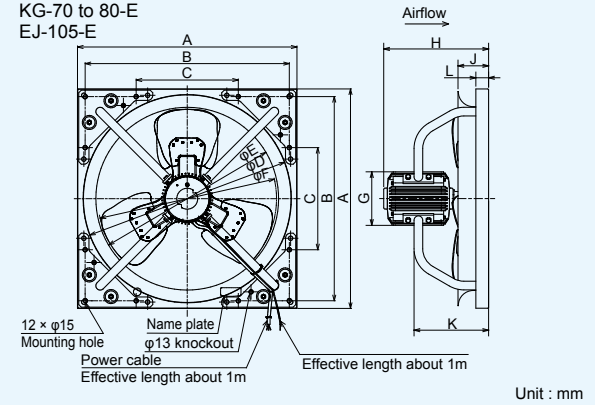

■Dimensions

Model	A	B	C	D	E	F	G	H	J	K	L	Power cable	Earth wire
EWF-45ETA-E	620	560	-	540	456	450	φ131	312	111	-	-	X	AWG18
EWF-50FTA-E	620	560	-	590	511	500	φ131	292	84	-	-	X	AWG18
EWG-60FTA-E	710	650	-	703	607	600	φ163	345	119	-	-	X	AWG18
KG-70GTF ₃ -E	860	800	400	816	716	700	φ210	412	120	292	50	Y	AWG18
KG-80HTF ₃ -E	950	900	400	910	816	800	φ230	451	120	332	55	Y	AWG18
EJ-105HTB-E	1280	1210	750	1270	1070	1050	φ255	547	200	437	50	Z	-

X : Vinyl cabtyre cable 3 conductors x 0.75mm²
Y : Vinyl cabtyre cable 3 conductors x 2.0mm²
Z : 4 conductors x 2.5mm²

■Specifications (50Hz)

Model	Power supply [V]	Number of poles	Power consumption [W]	Current [A]	Airflow rate [m ³ /h]	Noise [dB]	Weight [kg]	Indoor/outdoor use
EWF-45ETA-E	Three phase 380-440	4	250-270	0.66-0.75	5700	47.5	17.3	Outdoor use Indoor use
EWF-50FTA-E		4	330-355	0.78-0.82	7240	49.5	19.4	
EWG-60FTA-E		6	375-410	1.00-1.15	9700	47.5	25	
KG-70GTF ₃ -E		6	710-800	2.60-3.10	16000	62.5	52	
KG-80HTF ₃ -E		6	1020-1060	2.65-2.90	22800	66.5	62.5	
EJ-105HTB-E	Three-phase 380-415	10	1170-1240	5.1-5.5	27300	59	139.0	

■Specifications (60Hz)

Model	Power supply [V]	Number of poles	Power consumption [W]	Current [A]	Airflow rate [m ³ /h]	Noise [dB]	Weight [kg]	Indoor/outdoor use
EWF-45ETA-E	Three phase 380-440	4	360-380	0.71-0.72	6700	52.5	17.3	Outdoor use Indoor use
EWF-50FTA-E		4	510-530	0.91	8280	53.5-54	19.4	
EWG-60FTA-E		6	590-610	1.15	11160	51.5	25	
KG-70GTF ₃ -E		6	1040-1100	2.50-2.70	19000	67	52	
KG-80HTF ₃ -E		6	1570-1650	3.05	26000	71	62.5	
EJ-105HTB-E	Three-phase 400-440	10	1735-1790	4.9-4.9	32700	63	139.0	

P-Q Characteristics

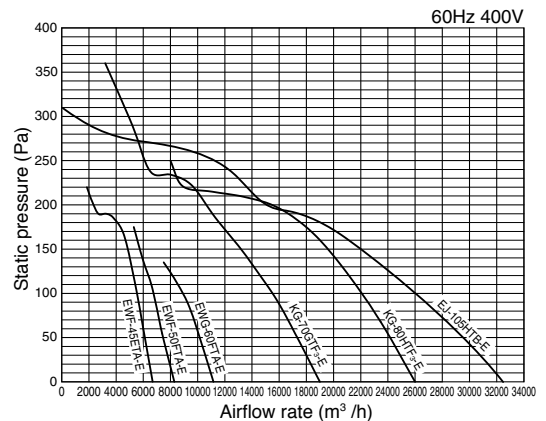
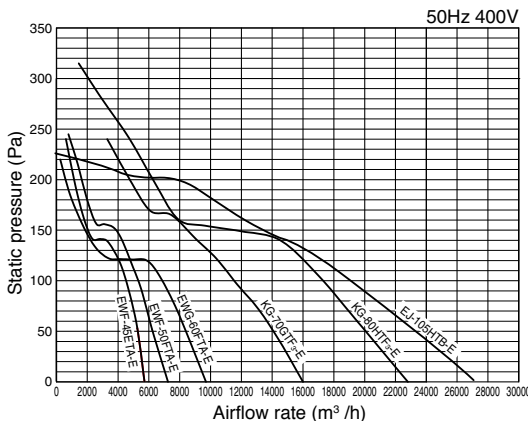

*Do not use the appliance out of the range of the characteristic curve.

The printed color of the products may differ slightly from the actual product colors. Due to continuous improvements, the above specifications are subject to change without notice.

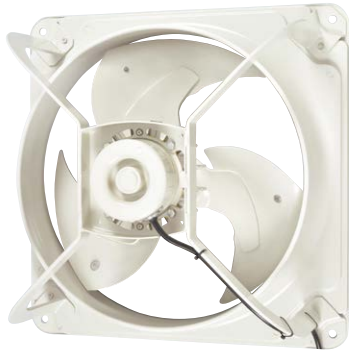

EWF-25 to 50-Q-E EWG-60-Q-E

(Supply type)

*25-60cm models are for supply use only (the direction of the vanes cannot be changed). For exhaust-use models, please see p.3-4.

*Operating conditions: Ambient temperature between -15°C and +50°C, and a relative humidity of 90% or less at normal temperature. Use outside of this range may result in burning, deformation, irregular rotation, or damage.

*Do not install the unit in a freezer or where freezing may occur.

*Avoid turning the unit on and off more than 50 times a day.

*Speed switching is not possible with this series.

*Do not install the indoor models outdoors where they will be exposed to direct rain.

*Outdoor models can be installed where they will be directly exposed to rain.

However, rust could shorten their service life.

*Do not connect the unit to an inverter (the insulation may break down due to a surge from the inverter).

Applicable for



■Specifications (50Hz)

Model	Power supply [V]	Number of poles	Power consumption [W]	Current [A]	Airflow rate [m³/h]	Noise [dB]	Weight [kg]	Indoor/outdoor use
EWF-25ASA-Q-E	Single-phase 220-240	4	39.5-45.5	0.19	1150	38	4.3	Indoor use
EWF-30BSA-Q-E		4	71.5-85	0.47-0.53	1680	44.5	5.8	
EWF-35DSA-Q-E		4	122-130	0.62	3000	48.5	9.5	
EWF-40DSA-Q-E		4	120-127	0.62	3720	50.5	12.1	
EWF-45ESA-Q-E		4	240-260	1.23	5560	56	18.3	
EWF-45ETA-Q-E	Three-phase 380-440	4	235-260	0.62-0.70	5700	56.5	17.8	Outdoor use Indoor use
EWF-50FTA-Q-E		4	320-340	0.84-0.93	7240	57.5	19.7	
EWG-60FTA-Q-E		6	400-430	1.03-1.15	9700	54-54.5	27.1	
KG-70GTF ₃ -E "Supply type"		6	810-900	2.70-3.20	15000	66.5	52	
KG-80HTF ₃ -E "Supply type"		6	1100-1130	2.70-2.85	20400	71	62.5	

■Specifications (60Hz)

Model	Power supply [V]	Number of poles	Power consumption [W]	Current [A]	Airflow rate [m³/h]	Noise [dB]	Weight [kg]	Indoor/outdoor use
EWF-25ASA-Q-E	Single-phase 220-240	4	49-55	0.23	1260	42	4.3	Indoor use
EWF-30BSA-Q-E		4	74-82	0.40-0.42	1900	48	5.8	
EWF-35DSA-Q-E		4	170-180	0.75	3500	53	9.5	
EWF-40DSA-Q-E		4	162-170	0.75-0.72	4200	54.5	12.1	
EWF-45ESA-Q-E		4	355	1.60-1.50	6370	60.5	18.3	
EWF-45ETA-Q-E	Three-phase 380-440	4	345-365	0.68	6700	61	17.8	Outdoor use Indoor use
EWF-50FTA-Q-E		4	490-500	0.90	8280	61.5	19.7	
EWG-60FTA-Q-E		6	590-625	1.16-1.18	11160	59.5	27.1	
KG-70GTF ₃ -E "Supply type"		6	1220-1270	2.70-2.90	18000	72	52	
KG-80HTF ₃ -E "Supply type"		6	1710-1800	3.2	24000	75	62.5	

KG-70GTF₃-E and KG-80HTF₃-E can be used as supply-type units by changing the direction of the vanes and wiring connection. Please refer to the manual on how to make these changes.

P-Q Characteristics

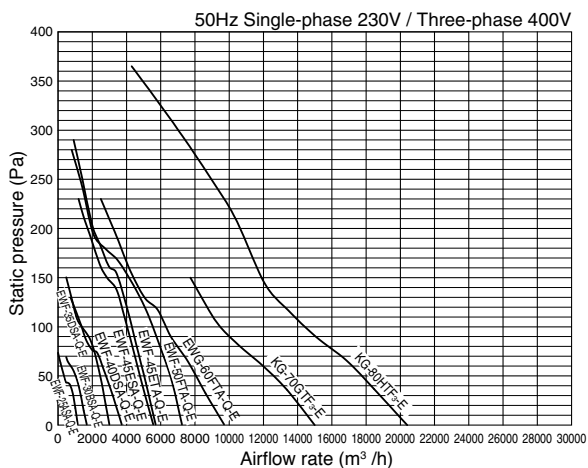

■Dimensions *The appearance may differ slightly depending on the model.
EWF/EWG-25 to 60-Q-E

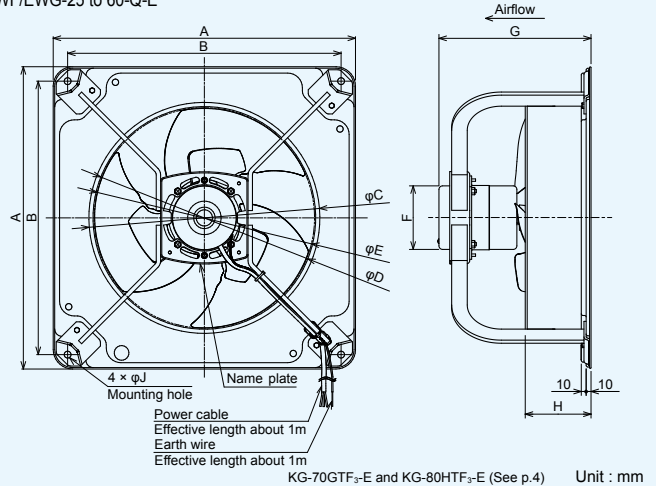

KG-70GTF₃-E and KG-80HTF₃-E (See p.4) Unit : mm

■Dimensions

Model	A	B	C	D	E	F	G	H	J	Power cable	Earth wire
EWF-25ASA-Q-E	370	330	283	266	260	153	201	110	10	A	-
EWF-30BSA-Q-E	420	380	323	306	300	153	197	110	10	A	-
EWF-35DSA-Q-E	470	434	373	356	350	181	259	130	10	A	-
EWF-40DSA-Q-E	520	460	423	406	400	181	266	135	14	A	-
EWF-45ESA-Q-E	620	560	473	456	450	211	307	135	14	A	-
EWF-45ETA-Q-E	620	560	473	456	450	φ131	312	135	14	B	AWG18
EWF-50FTA-Q-E	620	560	528	511	500	φ131	292	155	14	B	AWG18
EWG-60FTA-Q-E	710	650	624	607	600	φ163	345	175	14	B	AWG18

A : Vinyl cabtyre cable 3 conductors x AWG18
B : Vinyl cabtyre cable 3 conductors x 0.75mm²

The printed color of the products may differ slightly from the actual product colors.
Due to continuous improvements, the above specifications are subject to change without notice.

Optional Parts

Shutter (Wind Pressure Type)



PS-25 to 105SHA-E

*Operating conditions: Ambient temperature between -10°C and +50°C, and a relative humidity of 90% or less at normal temperature.
 *Do not install this product where it will be exposed to direct rain.
 *This product is for exhaust use only. For supply, use the grille instead.
 (Failure to heed this warning might damage the shutter.)
 *Please see the list on the back page for combined uses with the fan.

Applicable for

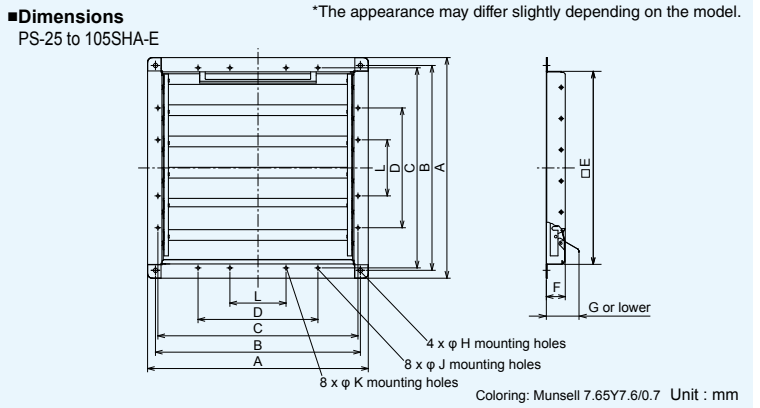

■Dimensions

Model	A	B	C	D	E	F	G	H	J	K	L	Number of blades	Weight [kg]
PS-25SHA-E	360	330	314	160	272	60	105	10	8	-	-	3	1.4
PS-30SHA-E	410	380	364	200	322	60	110	10	8	-	-	3	1.7
PS-35SHA-E	458	434	434	250	373	60	105	12	8	-	-	4	2.0
PS-40SHA-E	510	460	460	260	425	60	110	14	8	-	-	4	2.8
PS-50SHA-E	610	560	560	280	526	60	110	14	8	-	-	5	4.0
PS-60SHA-E	700	650	650	380	616	60	110	14	8	-	-	6	6.0
PS-70SHA-E	830	800	800	400	738	85	125	15	15	-	-	7	10.0
PS-80SHA-E	930	900	900	500	838	85	125	15	15	15	400	8	12.0
PS-105SHA-E	1240	1210	1210	750	1148	85	125	15	15	-	-	11	18.0

Pressure Loss Curve

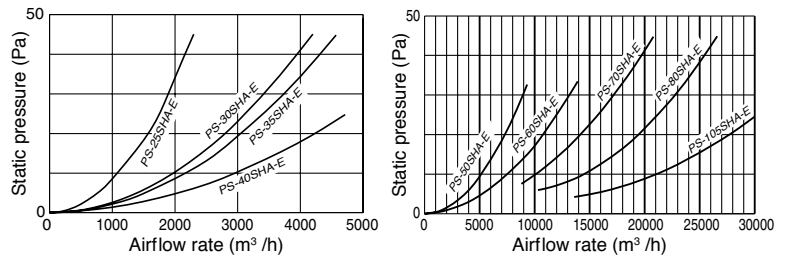

Grille



PS-25 to 60SK-E

*Operating conditions: Ambient temperature between -30°C and +80°C, and a relative humidity of 90% or less at normal temperature.
 *This product may be used for both exhaust and supply.
 *If the grille is used as a natural air inlet, use one that is larger than the size of the fan blade, or use two or more grilles.
 *Please see the list on the back page for combined uses with the fan.

Applicable for

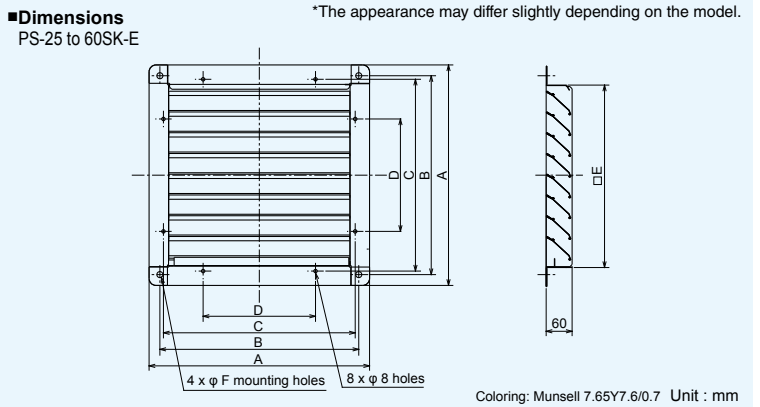

■Dimensions

Model	A	B	C	D	E	F	Number of blades	Weight [kg]
PS-25SK-E	360	330	314	160	273	10	5	1.7
PS-30SK-E	410	380	364	200	323	10	6	2.0
PS-35SK-E	458	434	434	250	371	12	7	2.6
PS-40SK-E	510	460	460	260	423	14	8	3.0
PS-50SK-E	610	560	560	280	524	14	10	4.5
PS-60SK-E	700	650	650	380	614	14	11	5.5

Pressure Loss Curve

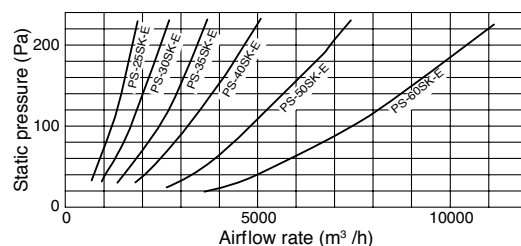

The printed color of the products may differ slightly from the actual product colors.
 Due to continuous improvements, the above specifications are subject to change without notice.

Optional Parts

Wire Guard (Made of Steel Wire)

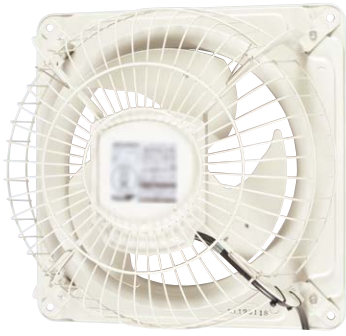

Coloring: Munsell 7.65Y7.6/0.7

*This product is used to protect the fan. Do not use it for any other purpose.
 *For your safety, install the fan more than 2.3m above the floor even when the wire guard is installed.
 *Please See the list below for combined uses with the fan.

Applicable for

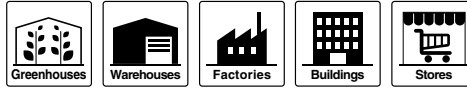

Weight

Model	Weight [kg]
G-25EC-E	0.4
G-30EC-E	0.5
G-35EC-E	0.6
G-40EC-E	0.8
G-50EC-E	1.3
G-60EC-E	1.6
G-70SB-E	2.6
G-80SB ₁ -E	2.9
G-105EB-E	4.6

G-25 to 60EC-E
G-70SB-E
G-80SB₁-E
G-105EB-E

Optional Parts Table for Each High-Pressure Fan

High pressure fan	Diameter of fan (cm)	Shutter	Grille	Wire guard
EWF-25ASA-E	25	PS-25SHA-E	PS-25SK-E	G-25EC-E
EWF-25ASA-Q-E		N/A		
EWF-30BSA-E	30	PS-30SHA-E	PS-30SK-E	G-30EC-E
EWF-30BSA-Q-E		N/A		
EWF-35DSA-E	35	PS-35SHA-E	PS-35SK-E	G-35EC-E
EWF-35DSA-Q-E		N/A		
EWF-40DSA-E	40	PS-40SHA-E	PS-40SK-E	G-40EC-E
EWF-40DSA-Q-E		N/A		
EWF-45ESA-E	45	PS-50SHA-E	PS-50SK-E	G-50EC-E
EWF-45ESA-Q-E		N/A		
EWF-45ETA-E		PS-50SHA-E		
EWF-45ETA-Q-E		N/A		
EWF-50FTA-E	50	PS-50SHA-E	PS-50SK-E	G-60EC-E
EWF-50FTA-Q-E		N/A		
EWG-60FTA-E	60	PS-60SHA-E	PS-60SK-E	G-60EC-E
EWG-60FTA-Q-E		N/A		
KG-70GTF ₃ -E	70	PS-70SHA-E	N/A	G-70SB-E
KG-70GTF ₃ -E (Supply type)		N/A		
KG-80HTF ₃ -E	80	PS-80SHA-E	N/A	G-80SB ₁ -E
KG-80HTF ₃ -E (Supply type)		N/A		
EJ-105HTB-E	105	PS-105SHA-E	N/A	G-105EB-E

The printed color of the products are slightly different from those of the actual products.
 Due to continuing improvement, above specifications may be subject to change without notice.

MITSUBISHI ELECTRIC CORPORATION

HEAD OFFICE : TOKYO BLDG., 2-7-3 MARUNOUCHI, CHIYODA-KU, TOKYO 100-8310, JAPAN
www.MitsubishiElectric.com